

Three-phase transformers with 3EI alternately stacked lamination are produced with electrical output power and dimensions according to table below. Voltage transfer 1-1000 V in any combination. Covering IP 00.

Type:

W - vertically mounted, terminal blocks like WAGO, RKW, RSA

DS - vertical, screw contacts on board

Other variations are available upon discussion with the engineering department.

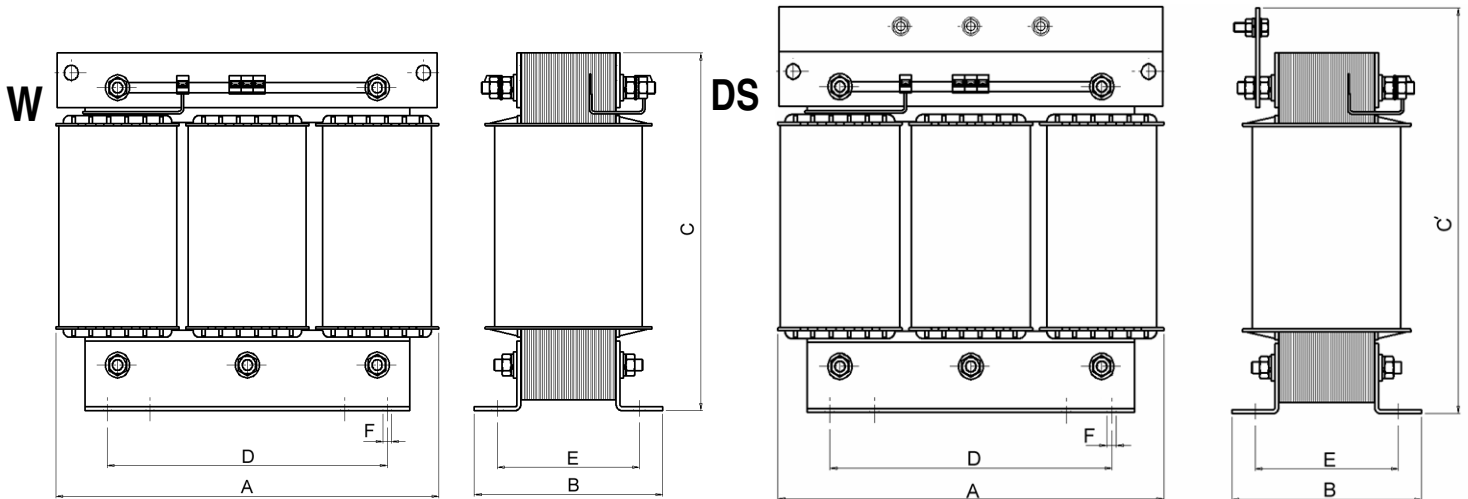

| Type | Style | Dimensions [mm] | | | | | | | Rated output according to core quality VA | | Core c.s. area cm ² | Core dimension mm | Weight (informative) kg |
|---|-------|-----------------|-----|-----|------|-----|-----|-----|---|-----------------------|--------------------------------|-------------------|-------------------------|
| | | C | C' | E | F | A | B | D | M400-50 | M111-35 | | | |
| 3x7070 | DS | 365 | 410 | 125 | 9x12 | 425 | 175 | 280 | 7000 | - | 48,0 | 350x350 | 100 |
| | W | 365 | - | 125 | 9x12 | 425 | 175 | 280 | | | | | |
| 3x70103 | DS | 365 | 410 | 155 | 9x12 | 425 | 205 | 280 | 8000 | - | 66,0 | 350x350 | 121 |
| | W | 365 | - | 155 | 9x12 | 425 | 205 | 280 | | | | | |
| 3x70133 | DS | 365 | 410 | 185 | 9x12 | 425 | 235 | 280 | 9000 | - | 89,0 | 350x350 | 160 |
| | W | 365 | - | 185 | 9x12 | 425 | 235 | 280 | | | | | |
| 3x8083 | DS | 445 | 457 | 160 | 13 | 475 | 195 | 356 | 10000 | 14500 | 62,0 | 400x400 | 146 |
| | W | 445 | - | 160 | 13 | 475 | 195 | 356 | | | | | |
| 3x80110 | DS | 445 | 457 | 185 | 13 | 475 | 225 | 356 | 12500 | 17000 | 82,0 | 400x400 | 170 |
| | W | 445 | - | 185 | 13 | 475 | 225 | 356 | | | | | |
| 3x80140 | DS | 445 | 457 | 215 | 13 | 475 | 255 | 356 | 14000 | 20000 | 105,0 | 400x400 | 212 |
| | W | 445 | - | 215 | 13 | 475 | 255 | 356 | | | | | |
| 3x80140 | DS | 445 | 457 | 215 | 13 | 475 | 255 | 356 | 25000 | Only general transfer | 105,0 | 400x400 | 212 |
| | W | 445 | - | 215 | 13 | 475 | 255 | 356 | | | | | |
| Following outputs are available upon discussion with the engineering department. | | | | | | | | | | | | | |
| 3x10080 | W | 505 | | 165 | 13 | 600 | 205 | 400 | 30000 | | 78,4 | 500x500 | 220 |
| | | | | | | | | | | | | | |
| 3x100100 | W | 505 | | 185 | 13 | 600 | 225 | 400 | 40000 | | 98,0 | 500x500 | 260 |
| | | | | | | | | | | | | | |
| 3x100120 | W | 505 | | 210 | 13 | 600 | 250 | 400 | 50000 | | 117,6 | 500x500 | 300 |
| | | | | | | | | | | | | | |
| 3x100140 | W | 505 | | 225 | 13 | 600 | 265 | 400 | 60000 | | 137,2 | 500x500 | 379 |
| | | | | | | | | | | | | | |



ELEKTROKOV, a.s. ZNOJMO

Kotkova 3582/19, 669 02 ZNOJMO, CR

tel.: +420 515 200 004-5, fax: +420 515 200 034

e-mail: obchodni@elektrov.cz, <http://www.elektrov.cz>

